



**ADHESIVE SYSTEMS
TECHNOLOGY CORP**

METER-MIX DISPENSE EQUIPMENT

PCV SP-5 GALLON SMART PUMP



APPLICATIONS

- Sealing
- Caulking

MATERIALS

- Silicones
- Single Part Urethanes
- Fire Stop

FEATURES AND BENEFITS

- Uses AST CMP metering pump
- Continuous flow up to 2 gpm
- Fluid pressures up to 3,000 psi
- Viscosities up to 1,000,000 cps
- 5:1 to 40:1 power factor ratio
- Adjustable flow rate
- 5 gallon feed with follower plate
- High pressure/self priming
- 6" or 8" diameter drive cylinder
- Pneumatic powered
- Metered shots or continuous flow
- Pumps abrasive materials

PCV SP-5 GALLON SMART PUMP



PRODUCT SPECIFICATIONS

Applications for the PCV SP-5 gallon Smart Pump for Silicones, Single-Part Urethanes, Epoxy, Fire Stop, and general adhesives include:

- Sealing
- Metering
- Caulking
- Cartridge Filling

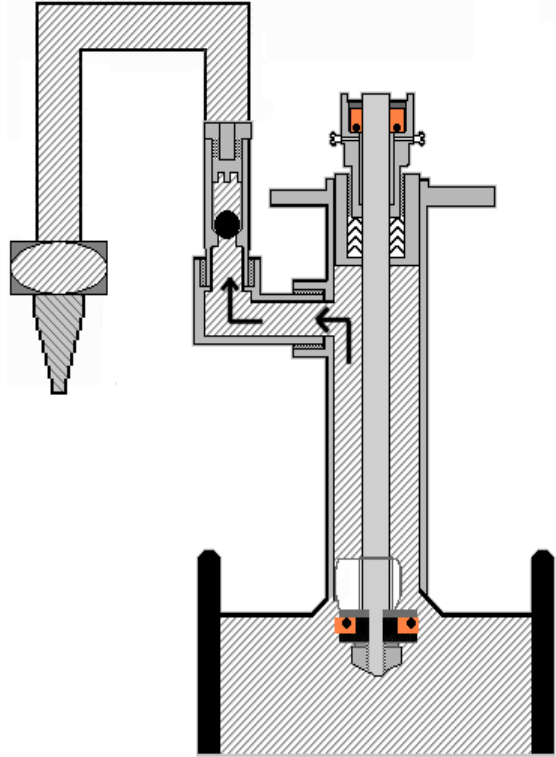

MODEL	PCV SP-5 CMP 632	CYCLE RATE	Up to 30 cycles per minute
DRIVE SYSTEM	6" – 8" Dia. Air Cylinder	DISPENSE MANIFOLD	Manual or Automatic; Fixed or hand-held
OUTPUT	Up to 2 gpm depending on size, viscosity & hose	POWER FACTOR	5:1 – 40:1
CONTAINERS	5 Gal.	SHOT SIZE	Up to 0.25 gal. per stroke
VISCOSITY RANGE	1 – 1,000,000 cps	STROKE SIZE	Up to 6" per stroke
ACCURACY	Within 2% of shot	SHOT ADJUSTMENT	0 - 100% of full stroke
POWER REQUIREMENT	10 cfm at 90 psi	OPTIONS	Power valves, pneumatic ram; heated pumps; 9" stroke; Pneumatic elevator/ram
SIZE	16" x 24" x 48"; 200 lbs.		

ADHESIVE SYSTEMS TECHNOLOGY CORP.
 9000 Science Center Drive, New Hope, MN 55428
 Phone: 763-592-2060 • Fax: 763-592-2075
 www.ast-corp.net • ast@ast-corp.net