

SINGLE COMPONENT PACKING DISPENSE VALVE

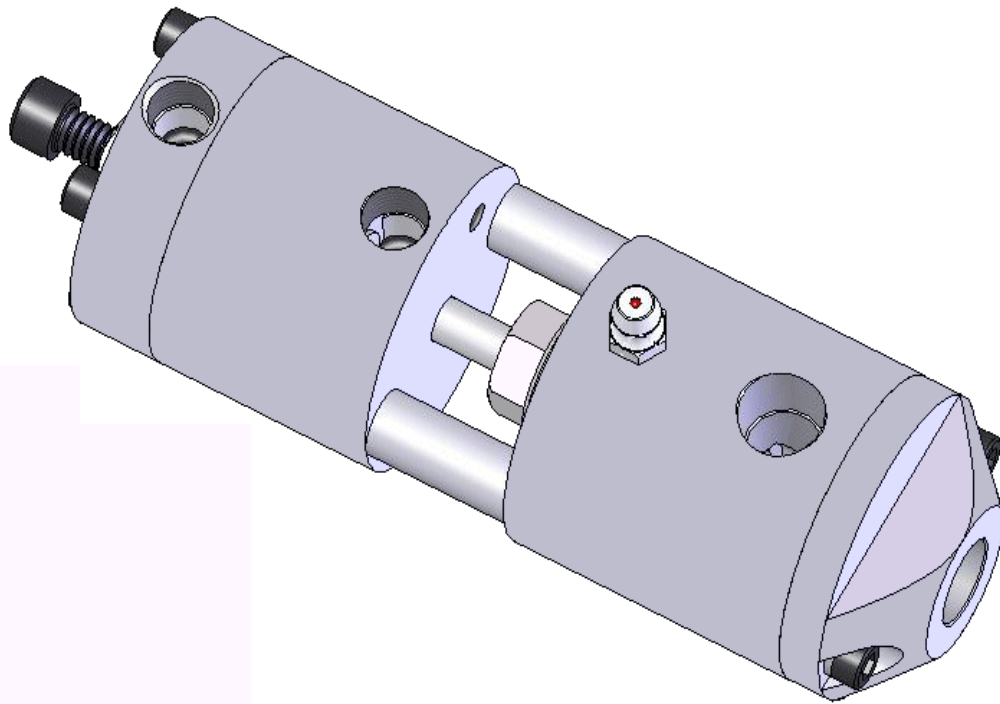

FEATURES AND BENEFITS

- Reliable, rugged design
- Easily adapts to automatic control
- Pneumatic operated/air to open/close
- Quick, easy fixture mounted and/or hand-held
- Pressure lube pack for longer seal life
- High volume flow
- Adjustable strobe length
- 1 cps to 2,500,000 cps materials
- Simple, modular design
- Straight shut-off valve

VALVE CROSS-SECTION

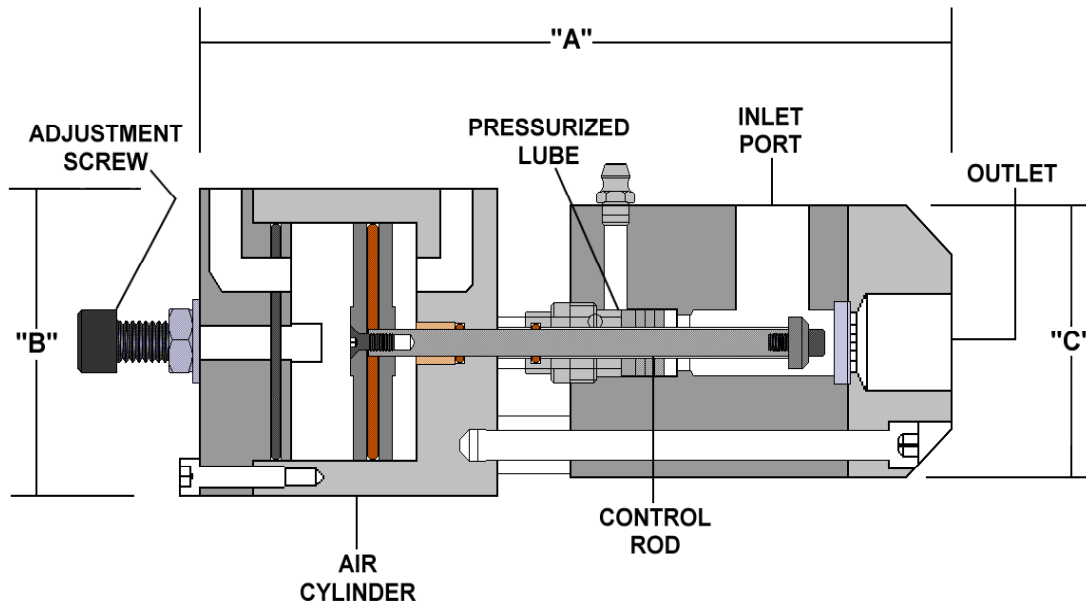

VALVE TECHNICAL DATA

DESCRIPTION	55655	55656
INLET PORT	½" NPT F	¼" NPT F
OUTLET PORT	½" NPT F	¼" NPT F
ROD DIAMETER	¼"	¼"
WORKING PRESSURE	1,600 psi	2,500 psi
SEALS/ O-RINGS	Teflon (tensionable), UHMW, Viton, EPDM, Buna, Silicone	
A	7-½"	6-1/8"
B	2-¼" DIA.	1-¾" DIA.
C	2" DIA.	1-¾" DIA.